

# ACTUATOR DRIVER WITH CURRENT FEEDBACK FOR CD – ROM/DVD—YD5954

## DESCRIPTION

The YD5954 is a four-channel BTL driver IC for driving the motors and actuators in products such as CD-ROM/DVD drivers. Two of the channels use current feedback to minimize the current phase shift caused by the influence of load inductance.

## FEATURES

- \*Wide dynamic range(4.0V(typ.) when  $V_{CC}=12V$ ,  $PV_{CC}=5V$ , and  $R_L=8 \Omega$  ).
- \*Level shift circuit on chip.
- \*Thermal shutdown circuit on chip.

## BLOCK DIAGRAM

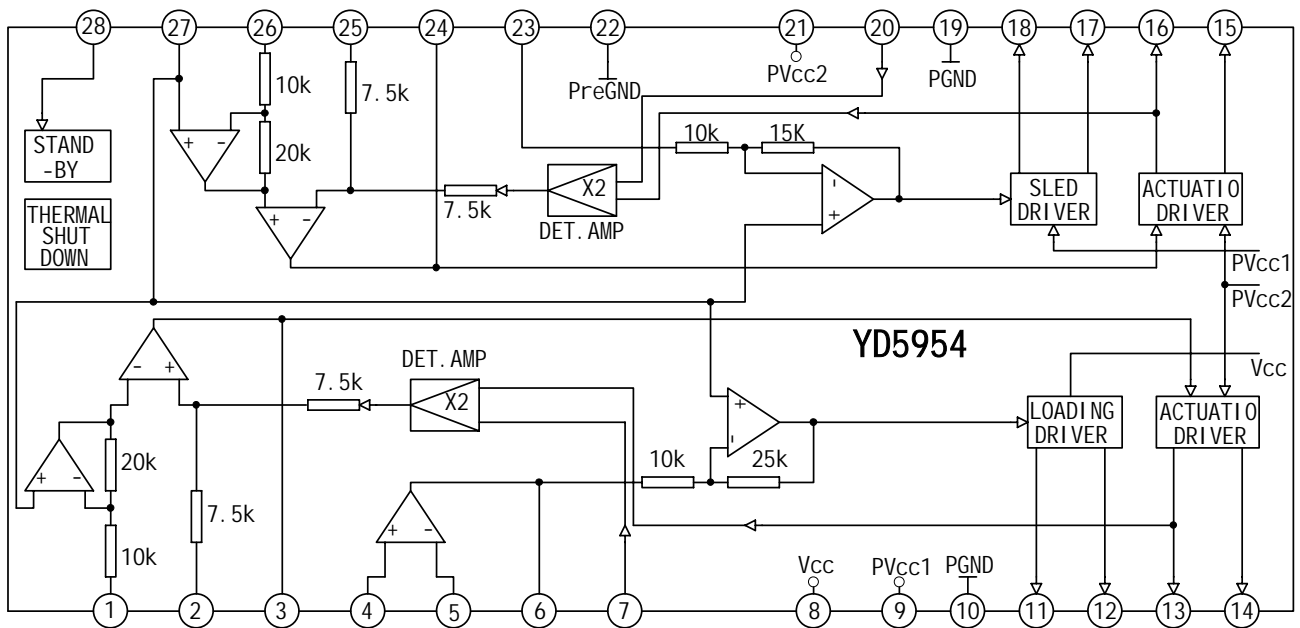

### WuXi YouDa Electronics Co., Ltd

**Add:** No.5 Xijin Road, National Hi-Tech Industrial Development Zone, Wuxi Jiangsu China  
**Tel:** 86-510-5205117 86-510-5205108 **Fax:** 86-510-5205110 **Website:** www.e-youda.com  
**SHENZHEN OFFICE Tel :** 86-755-83740369 13823533350 **Fax :** 86-755-83741418

**ABSOLUTE MAXIMUM RATINGS** (Tamb=25 )

PARAMETER	SYMBOL	VALUE	UNIT
Power Supply Voltage	$V_{CC}, PV_{CC1}/2$	13.5	V
Power Dissipation	$P_D$	1.7	W
Operating Temperature	$T_{opr}$	-34 to +85	
Storage Temperature	$T_{stg}$	-55 to +150	

**ELECTRICAL CHARACTERISTICS**

(Unless other specified, Tamb=25 , Vcc=12V, Pvcc1=Pvcc2=5V, BIAS=2.5V, RL=8., Rd=0.5, C= 100pF)

PARAMETER	SYMBOL	TEST CONDITIONS	MIN	TYP	MAX	UNIT
Quiescent Current	Icc			18	27	mA
<b>Actuator Driver</b>						
Output Offset Current	$I_{OOF}$		-6		6	mA
Maximum Output Amplitude	$V_{OM}$		3.6	4.0		V
Transmission Gain	$G_M$	$V_{IN}=BIAS \pm 0.2V$	1.3	1.5	1.7	A/V
<b>Loading Driver</b>						
Input op-amp Same Phase Input Range	$V_{ICM}$		-0.3		11.0	V
Input Bias Current (outflow current)	$I_{BOP}$			30	300	nA
Output High Level Voltage	$V_{OHOP}$	No load	10.8	11.1		V
Output Low Level Voltage	$V_{OLOP}$	No load		0.8	1.1	V
Output Offset Voltage	$V_{OOFLD}$		-100	0	100	mV
Maximum Output Amplitude	$V_{OMLD}$		7.5	9.0		V
Closed-circuit Voltage Gain	$G_{VLD}$	$V_{IN}=BIAS \pm 0.2V$	18.0	20.0	22.0	dB
<b>Sled Driver</b>						
Offset Voltage	$V_{OOFSL}$		-50	0	50	mV

Maximum Output Amplitude	$V_{OMSL}$		3.6	4.0		V
Voltage Gain	$G_{VSL}$	$V_{IN}=BIAS \pm 0.2V$	13.5	15.5	17.5	dB
F/R Gain Differential	$\Delta G_{VSL}$	$V_{IN}=BIAS \pm 0.2V$	0	1	2	dB
<b>STBY Logic</b>						
STBY On Voltage	$V_{STBY1}$	All Channels Off	0		0.5	V
STBY Off Voltage	$V_{STBY2}$	All Channels On	2.0			V

**APPLICATION CIRCUIT**

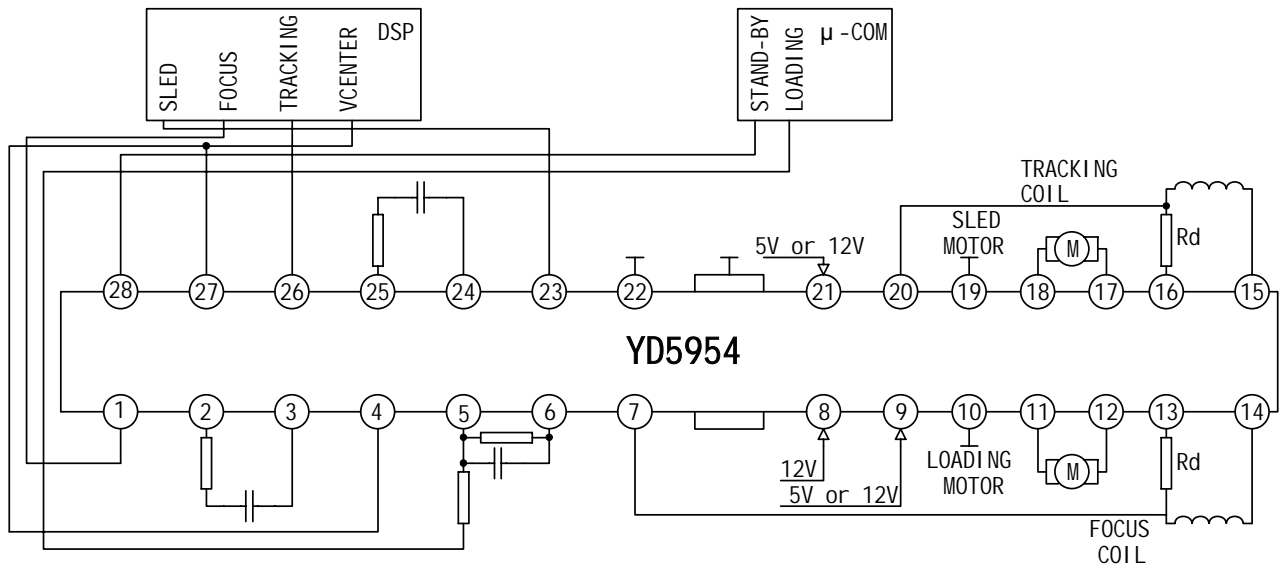

OUTLINE DRAWING

